

Types 3214/3374, 3214/3274, 3214/3375 Electric Control Valves

Type 3214 Globe Valve balanced by a diaphragm



Application

Control valves with globe valves balanced by a diaphragm for HVAC applications

DN 65 to 400 · PN 16 to 40

Up to 150 °C (water)

Up to 80 °C (non-flammable gases)



The control valves consist of a Type 3214 Globe Valve balanced by a diaphragm and an electric or electrohydraulic actuator.

Special features

- Very high K_{VS} coefficients
- Soft-seated plug to minimize seat leakage
- Seat/plug trim made of red brass or brass with stainless steel (DN 65 to 100)
- Low overall height compared to version balanced by a bellows
- Actuators with fail-safe action or without fail-safe action

Versions

Version tested according to DIN EN 14597		
Type 3214/3374	PN 16 to 25	DN 65 to 100
Type 3214/3274	PN 16 to 40	DN 125 to 150

Electric control valves		
Type 3214/3374 · Fig. 1	PN 16 to 25	DN 65 to 100
Type 3214/3274 or Type 3214/3374	PN 16 to 40	DN 125 to 250
Type 3214/3375	PN 16 to 40	DN 300 to 400

Register number

The actuators with fail-safe action in conjunction with the listed valves are tested by the German Technical Inspectorate (TÜV) according to DIN EN 14597. The register number is available on request.

Also available:

Type 3214 Globe Valve **balanced by a bellows**:

- Control valves with electric, electrohydraulic or pneumatic actuator without fail-safe action, see Data Sheet ▶ T 5868
- Control valves tested according to DIN EN 14597 with electric actuator with fail-safe action, see Data Sheet ▶ T 5869



Fig. 1: Type 3214/3374
Globe Valve Type 3214 balanced by a diaphragm

Principle of operation

The medium flows through the globe valve in the direction indicated by the arrow on the valve body. The cross-sectional area of flow between the seat (2) and plug (3) is determined by the position of the plug stem.

The downstream pressure p_2 is applied to the inside of the Type 3214 Valve and the upstream pressure p_1 acts on the outside. The forces acting on the valve plug due to the upstream and downstream pressures are balanced by the diaphragm (4).

The plug is moved by changing the control signal applied to the actuator. For the Type 3374 and Type 3375 Electric Actuators as well as the Type 3274 Electrohydraulic Actuator, this signal is a three-step signal. The actuators (except for Type 3375) can also be controlled in the version with positioner by a 0/4 to 20 mA or 0/2 to 10 V signal. Various electrical accessories can be optionally installed.

The electric actuators can be equipped with additional accessories.

Refer to data sheet for details

Type 3374 ► Data Sheet T 8331

Type 3274 ► Data Sheet T 8340

Type 3375 ► Data Sheet T 8332

Installation

- Install the valves in horizontal pipelines.
- The direction of flow must match the direction indicated by the arrow on the valve body
- Install the valve with the balancing diaphragm or actuator in upright position, facing upward.
- Install a strainer (e.g. SAMSON Type 2 N or Type 2 NI) upstream of the valve.

Ordering text

Type 3214/3374, 3214/3274 or 3214/3375 Electric Control Valve balanced by a diaphragm

- DN ..., PN ..., K_{VS} ...
- Max. differential pressure Δp ... bar, max. temperature ... °C
- Body material ...

Legend for Fig. 2

1	Valve body	5	Yoke
2	Seat	6	Plug stem
3	Plug	8	Actuator
4	Balancing diaphragm	10	Stem connector

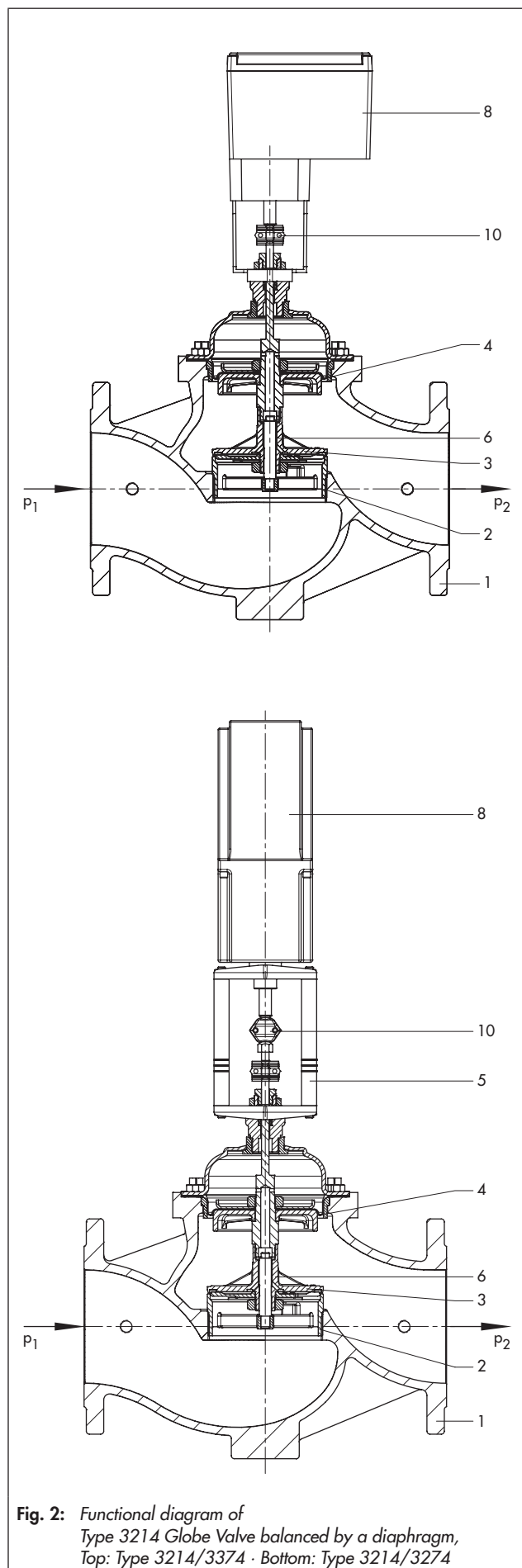

Fig. 2: Functional diagram of
Type 3214 Globe Valve balanced by a diaphragm,
Top: Type 3214/3374 · Bottom: Type 3214/3274

Table 1: Technical data

Nominal size	DN	65	80	100	125	150	200	250	300	400
Nominal pressure	PN	16 and 25			16 to 40					
Rated travel	mm	15	15	15	30	30	30	30	50	60
K _{V5} coefficient		50	80	125	230	340	620	750	1200	2000
Max. perm. diff. pressure Δp	bar	10	10	10	12	12	10	10	10	6
Max. permissible temperature	°C									
Version for water		150								
Version for non-flammable gases		80								
Rangeability		40:1			30:1					
Leakage class according to IEC 60534-4		Class I (≤ 0.01 % of K _{V5} coefficient)								
Compliance										

Table 2: Materials · Material numbers according to DIN EN

Nominal size	DN	65	80	100	125	150	200	250	300	400
Body	PN 16	EN-GJL-250 (EN-JL1040) EN-GJS-400-18-LT (EN-JS1049)			EN-GJL-250 (EN-JL1040)		EN-GJL-250 (EN-JL1040)		EN-GJL-250 (EN-JL1040) 1.6019	
	PN 16/25				EN-GJS-400-18-LT (EN-JS1049)		-			
	PN 16, 25 and 40				1.0619		1.0619			
Valve seat		1.4408			CC491K				1.4301	
Plug		CW617N with EPDM soft seal			CC491K with EPDM soft seal				1.4301 with EPDM soft seal	
Pressure balancing		EPDM balancing diaphragm								

Table 3: Possible combinations: Type 3214 Globe Valve with balancing diaphragm/actuator

Actuator	Type	Refer to data sheet for details	Nominal size								
			65	80	100	125	150	200	250	300	400
Without fail-safe action	3274-12 ¹⁾	▶ T 8340	-	-	-	•	•	•	•	-	-
	3274-16 ¹⁾		-	-	-	•	•	•	•	-	-
	3374-10	▶ T 8331	-	-	-	•	•	•	•	-	-
	3374-11		•	•	•	-	-	-	-	-	-
	3375-11		▶ T 8332	-	-	-	-	-	-	-	•
With fail-safe action	3274-23 ¹⁾	▶ T 8340	-	-	-	•	•	•	•	-	-
	3374-21	▶ T 8331	•	•	•	-	-	-	-	-	-
	3375-21 ²⁾	▶ T 8332	-	-	-	-	-	-	-	•	•
	3375-31 ²⁾		-	-	-	-	-	-	-	•	•

¹⁾ The rod-type yoke (1400-8822) is additionally required to connect Type 3274 Actuators.

²⁾ Types 3375-21/-31 Actuators in preparation

NOTE

Risk of valve damage due to excessively high forces.

When the valves are combined with pneumatic actuators, the maximum forces of the electric actuators listed in Table 3 must not be exceeded. If necessary, restrict the supply pressure.

Table 4: Dimensions and weights with actuator

Nominal size	DN	65	80	100	125	150	200	250	300	400
Length L	mm	290	310	350	400	480	600	730	850	1100
Height H1	mm	163	163	189	286	291	361	361	386	486
Height H2	mm	98	98	118	145	175	270	270	285	372
Height H	mm									
Type 3214/3274-12/-23		-	-	-	780	805	875	875	-	-
Type 3214/3274-16		-	-	-	875	900	970	970	-	-
Type 3214/3374-10/-11/21		457	457	483	580	585	655	655	-	-
Type 3214/3375-11		-	-	-	-	-	-	-	1100	1200
Type 3214/3375-21/-31		-	-	-	-	-	-	-	1205	1305
Weight ¹⁾	kg (approx.)									
Type 3214/3274 ²⁾		-	-	-	61	81	223	233	-	-
Type 3214/3374		30	34	44	52	72	214	224	-	-
Type 3214/3375 ³⁾		-	-	-	-	-	-	-	335	650

¹⁾ Valves in PN 16; versions in PN 25 and 40: +15 %

²⁾ Add 3 kg for Type 3274-16

³⁾ Add for 8 kg for Type 3375-21/-31

Dimensions in mm

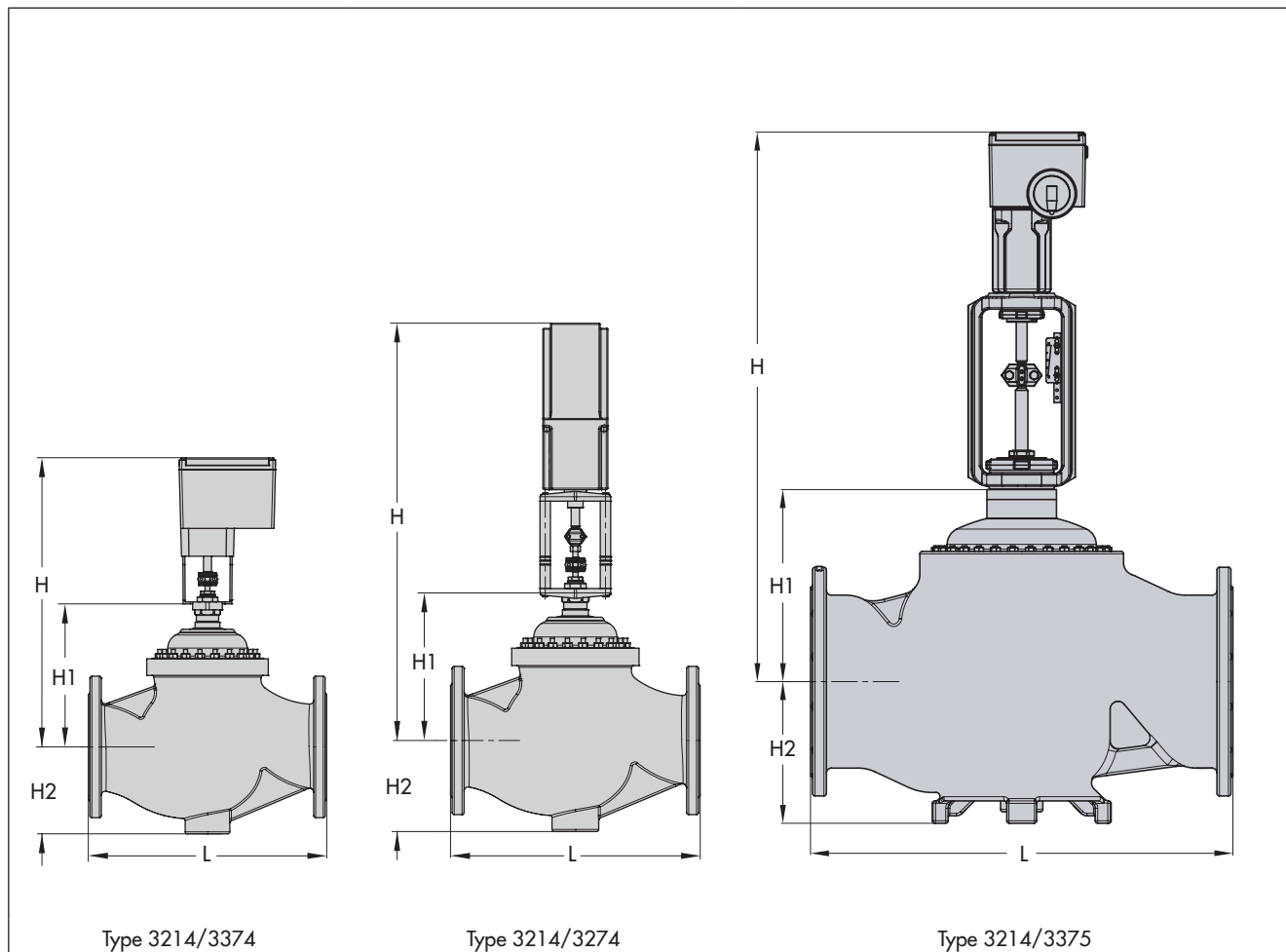

Specifications subject to change without notice



SAMSON AG · MESS- UND REGELTECHNIK
 Weismüllerstraße 3 · 60314 Frankfurt am Main, Germany
 Phone: +49 69 4009-0 · Fax: +49 69 4009-1507
 samson@samson.de · www.samson.de

T 5868-1 EN

2017-06-14 · English