

Series 290

Type 3296-1 and Type 3296-7 Pneumatic Control Valves

Type 3296 Angle Valve

ANSI version



Application

Control valve for process engineering applications with high industrial requirements

Valve size NPS ½ to 8

Pressure rating Class 150 to 900

Temperatures -325 to +842 °F (-198 to +450 °C)



Type 3296 Angle Valve with

- Type 3271 Pneumatic Actuator (Type 3296-1 Control Valve)
- Type 3277 Pneumatic Actuator (Type 3296-7 Control Valve) for integral positioner attachment

Valve body made of

- Cast steel
- High-temperature cast steel
- Cold-resisting cast steel
- Cast stainless steel

Valve plug

- Metal seal
- Soft seal
- High-performance metal seal
- Balanced to handle high differential pressures
- Quick and easy maintenance
- Clamped-in seat for quick maintenance

The control valves, designed according to the modular assembly principle, can be equipped with various accessories: Positioners, solenoid valves, and other accessories according to IEC 60534-6 and NAMUR recommendation. Details in Information Sheet ▶ T 8350.

Versions

Standard version (Fig. 1) · Angle valve with PTFE packing for temperatures from 14 to 430 °F (-10 to 220 °C) · NPS ½ to 8

- **Type 3296-1** (Fig. 1) · Type 3296 Valve with Type 3271 Actuator
- **Type 3296-7** · Type 3296 Valve and Type 3277 Pneumatic Actuator for integral positioner attachment (see Data Sheet ▶ T 8310-1)

Further versions

- **Welding ends or welding-neck ends** according to ANSI B16.25
- **Flow divider** · For noise reduction · Refer to Data Sheet ▶ T 8081
- **Perforated plug trim** · Refer to Data Sheet ▶ T 8086



Fig. 1: Type 3296-1 Control Valve with Type 3271 Pneumatic Actuator, positioner and solenoid valve

- **Insulating section or bellows seal** · See Technical data
- **Heating jacket** · Details on request
- **Additional handwheel** · See Data Sheets ▶ T 8310-1 and ▶ T 8310-2)
- **Type 3296-3 Hand-operated Valve** · With Type 3273 Hand-operated Actuator for valves with max. 30 mm rated travel · See Data Sheet ▶ T 8312
- **Type 3296-2 Electric Control Valve** · Details on request
- **NACE version for sour gas applications** · On request

Principle of operation (Fig. 2 to Fig. 4)

The medium flows through the valve in the direction indicated by the arrow. The valve plug position determines the free area between the valve seat and the plug.

The version with bellows seal (Fig. 4) is fitted with a test connection to monitor the stainless steel bellows.

Pressure balancing must be used when high pressures or differential pressures act on the plug and the actuator is unable to produce enough force to counteract the resulting forces.

The valves can be equipped with a flow divider St I (see Data Sheet ► T 8081) for noise reduction.

Fail-safe position

Depending on how the springs are arranged in the pneumatic actuator (see Data Sheets ► T 8310-1 and ► T 8310-2), the valve has two different fail-safe positions effective upon air supply failure.

- **Actuator stem extends (fail-close):** The valve closes when the supply air fails.
- **Actuator stem retracts (fail-open):** The valve opens when the supply air fails.

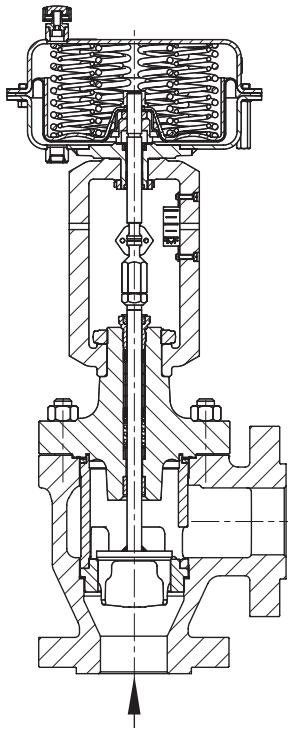

Fig. 2: Type 3296-1 Control Valve with Type 3271 Actuator

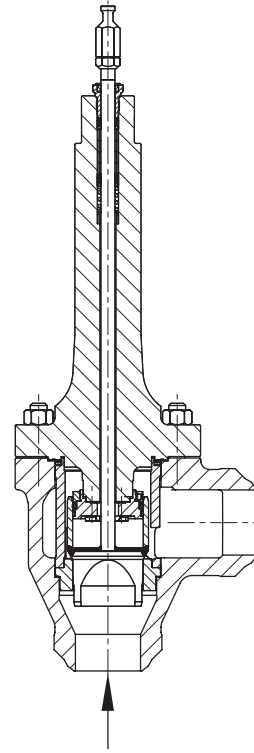

Fig. 3: Type 3296 with welding ends and insulating section

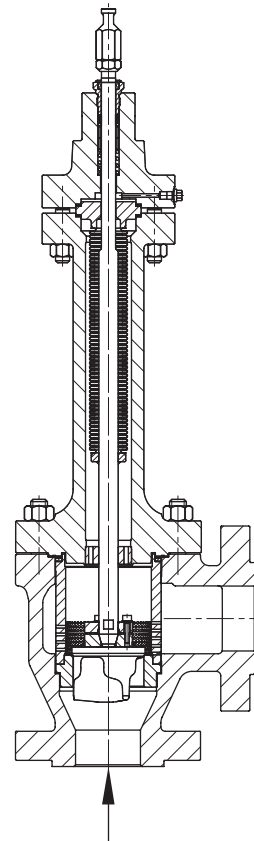



Fig. 4: Type 3296 Valve with bellows seal

Table 1: Technical data for Type 3296

Material	Cast steel A352 LCC	Cast steel A216 WCC	Cast steel A217 WC6	Cast stainless steel		
				A351 CF3M	A351 CF8M	
Valve size	NPS ½ to 8					
Pressure rating	Class 150 to 900					
Type of connection	Flanges	All ANSI versions				
	Welding ends	According to ANSI B16.25				
Seat-plug seal	Metal seal · Soft seal · High-performance metal seal					
Characteristic	Equal percentage · Linear · Quick opening					
Rangeability	50:1					
Compliance						
Temperature ranges in °F (°C) · Permissible operating pressures according to pressure-temperature diagrams (see Information Sheet ▶ T 8000-2)						
Body without insulating section	14 to 428 °F (-10 to +220 °C) · Up to 660 °F (350 °C) with high-temperature packing depending on material					
Body with	Insulating section	-51 to +649 °F (-46 to +343 °C)	-20 to +800 °F (-29 to +427 °C)	-20 to +842 °F (-29 to +450 °C)	-325 to +842 °F (-198 to +450 °C)	-325 to +842 °F (-198 to +450 °C)
	Bellows seal	-51 to +649 °F (-46 to +343 °C)	-20 to +800 °F (-29 to +427 °C)	-20 to +842 °F (-29 to +450 °C)	-325 to +842 °F (-198 to +450 °C)	-325 to +842 °F (-198 to +450 °C)
Valve plug ¹⁾	Standard	Metal seal: -325 to +842 °F (-198 to +450 °C)				
		Soft seal: -325 to +428 °F (-198 to +220 °C)				
		Balanced with PTFE ring: -40 to +428 °F (-40 to +220 °C) · Lower temperatures on request				
		Balanced with graphite ring: -40 to +842 °F (-40 to +450 °C)				
Leakage class according to ANSI/FCI 70-2 (2006)						
Valve plug	Standard	Metal seal: IV · High-performance metal seal: V				
		Soft seal ²⁾ : VI				
		Balanced, metal seal: Standard: IV (with PTFE or graphite ring) High-performance metal seal: V (only with PTFE ring)				

¹⁾ Only in combination with suitable body material

²⁾ On request

Table 2: Materials (EN material number)

Standard version Body and flanges ¹⁾	Cast steel A352 LCC	Cast steel A216 WCC	Cast steel A217 WC6	Cast stainless steel	
				A351 CF3M	A351 CF8M
Seat and plug ²⁾	Metal seal: 1.4006/1.4404	1.4006/1.4404	1.4006/1.4404	1.4404	1.4404
Seal ring for	Soft seal: PTFE with 15 % glass fiber				
	Pressure balancing: PTFE with carbon · Graphite				
Guide bushings	1.4112		1.4112	2.4610	
Packing	V-ring packing: PTFE with carbon; spring: 1.4310 · High-temperature packing				
Body gasket	Graphite seal on metal core				
Insulating section ³⁾	A352 LCC/ A350 LF2	A216 WCC/ A182 F12 Cl. 2/ A105	A217 WC6/ A182 F12 Cl. 2	A351 CF3M/ A182 F316L	A351 CF8M/ A182 F316
Metal bellows seal					
Intermediate piece ³⁾	A352 LCC/ A350 LF2	A216 WCC/ A182 F12 Cl. 2/A105	A217 WC6/ A182 F12 Cl. 2	A351 CF3M/ A182 F316L	A351 CF8M/ A182 F316
Metal bellows	1.4571				
Heating jacket	1.4404/A240 316L				

¹⁾ See also pressure-temperature diagrams (▶ T 8000-2)

²⁾ Seats and metal-seated plug also with Stellite® facing or plug made of solid Stellite® available

³⁾ Depending on valve bonnet material

Table 3: C_v and K_{VS} coefficients · Class 150 to 600

Versions highlighted in gray also available with balanced plug

Table 3.1: Overview with flow divider St I (C_{vI}/K_{vSI})

C_v	0.12	0.2	0.3	0.5	0.75	1.2	2	3	5	7.5	10.5	12	20	23	30	42	47	75	105	120	170	190	290	375	420	650
K_{VS}	0.1	0.16	0.25	0.4	0.63	1.0	1.6	2.5	4	6.3	9	10	16	20	25	36	40	63	90	100	144	160	250	320	360	560
C_{vI}	-								4.2	7	9.5	-	17	21	26	37	42	67	95	105	145	170	265	325	375	570
K_{vSI}	-								3.6	5.7	8	-	14.5	18	22	32	36	57	80	90	125	144	225	280	320	490
Seat Ø mm	6/8						12		24				31	38	50	63	80	100	125	150	200					
Rated travel	in	0.5											1.18					2.36								
	mm	15											30					60								

Table 3.2: Versions without flow divider

C_v	0.12	0.2	0.3	0.5	0.75	1.2	2	3	5	7.5	10.5	12	20	23	30	42	47	75	105	120	170	190	290	375	420	650	
NPS																											
1/2	•	•	•	•	•	•	•	•	•	•																	
1	•	•	•	•	•	•	•	•	•	•	•																
1½	•	•	•	•	•	•	•	•	•	•		•	•	•													
2									•	•		•	•		•	•											
3									•	•		•	•		•	•	•	•									
4															•	•	•	•	•	•	•	•					
6																		•	•	•	•	•	•	•	•	•	
8																						•	•	•	•	•	

Table 3.3: Versions with flow divider St I

C_{vI}	-								4.2	7	9.5	-	17	21	26	37	-	67	95	105	145	170	265	325	375	570	
NPS																											
1/2																											
1									•	•	•																
1½													•	•													
2															•	•											
3																	•	•									
4																			•	•							
6																					•	•	•	•	•	•	
8																									•	•	

Table 4: C_V and K_{VS} coefficients · Class 900

Versions highlighted in gray also available with balanced plug

Table 4.1: Overview with flow divider St I (C_{Vl}/K_{VSl})

C_V	0.12	0.2	0.3	0.5	0.75	1.2	2	3	5	7.5	9.5	12	20	21	30	37	47	75	95	120	145	190	290	325	420	570
K_{VS}	0.1	0.16	0.25	0.4	0.63	1.0	1.6	2.5	4	6.3	8	10	16	18	25	32	40	63	80	100	125	160	250	280	360	490
C_{Vl}	-								4.2	7	9.5	-	17	21	26	37	42	67	95	105	145	170	265	325	375	570
K_{VSl}	-								3.6	5.7	8	-	14.5	18	22	32	36	57	80	90	125	144	225	280	320	490
Seat \varnothing mm	6/8						12		24				31	38	50		63		80		100		125	150		200
Rated travel	in 0.5														1.18						2.36					
	mm 15														30						60					

Table 4.2: Versions without flow divider

C_V	0.12	0.2	0.3	0.5	0.75	1.2	2	3	5	7.5	9.5	12	20	21	30	37	47	75	95	120	145	190	290	325	420	490	
NPS																											
1/2	•	•	•	•	•	•	•	•	•																		
1	•	•	•	•	•	•	•	•	•	•	•																
1 1/2	•	•	•	•	•	•	•	•	•	•	•	•	•	•													
2									•	•		•	•		•	•											
3									•	•		•	•		•		•	•	•								
4															•		•	•		•	•						
6																		•		•		•	•	•			
8																							•	•		•	•

Table 4.3: Versions with flow divider St I

C_{Vl}	-								4.2	7	9.5	-	17	21	26	37	-	67	95	-	145	170	265	325	375	490			
NPS																													
1/2																													
1									•	•	•																		
1 1/2													•	•															
2														•	•														
3																		•	•										
4																					•								
6																						•	•	•					
8																										•	•		

Table 5: Dimensions for Type 3296-1 and Type 3296-7 in standard version

Table 5.1: Type 3296 Valve

Valve		NPS	½	1	1½	2	3	4	6	8	
		DN	15	25	40	50	80	100	150	200	
Length L1	Class 150	in	3.62	3.62	4.37	5.0	5.88	6.94	8.88	10.69	
		mm	92	92	111	127	149	176	226	272	
	Class 300	in	3.75	3.88	4.62	5.25	6.25	7.25	9.31	11.19	
		mm	95	99	117	133	159	184	236	284	
	Class 600	in	4.00	4.12	4.94	5.62	6.62	7.75	10.00	12.00	
		mm	101	105	125	143	168	197	254	305	
Class 900	in	4.25	5.00	6.00	7.25	7.50	9.00	12.00	14.50		
	mm	108	127	152	184	190	229	305	368		
Height H4	Class 150 to 600	in	5.28	5.08	5.08	6.89	6.30	6.69	9.17	On request	
		mm	134	129	129	175	160	170	233		
	Class 900	in	6.89	6.69	6.69	8.70	6.30	6.69	9.17		
		mm	175	170	170	221	160	170	233		
H8 for actuator	350 cm ²	in	9.45	9.45	9.45	9.45	9.45	9.45	-		
		mm	240	240	240	240	240	240			
	355 cm ²	in	9.45	9.45	9.45	9.45	9.45	9.45	15.55	-	
		mm	240	240	240	240	240	240	395		
	700 cm ²	in	9.45	9.45	9.45	9.45	9.45	9.45	15.55	15.55	
		mm	240	240	240	240	240	240	395	395	
	1000 cm ²	in	-				11.61	11.61	11.61	15.55	15.55
		mm	-				295	295	295	395	395
	1400-60 cm ²	in	-				11.61	11.61	11.61	15.55	15.55
		mm	-				295	295	295	395	395
	1400-120 cm ²	in	-						18.90	18.90	18.90
		mm	-						480	480	480
2800 cm ²	in	-						18.90	18.90	18.90	
	mm	-						480	480	480	

Table 5.2: Types 3271 and 3277 Pneumatic Actuators

Actuator area	cm ²	350	355	700	1000	1400-60	1400-120	2800	2 x 2800
Diaphragm ØD	in	11.02	11.02	15.35	18.19	20.87	21.02	30.32	30.32
	mm	280	280	390	462	530	534	770	770
H ¹⁾	in	3.23	4.76	7.83	15.87	11.3	19.29 ³⁾ / 22.83 ⁴⁾	24.80 ³⁾ / 27.36 ⁴⁾	44.49 ³⁾ / 47.05 ⁴⁾
	mm	82	121	199	403	287	490 ³⁾ / 580 ⁴⁾	630 ³⁾ / 695 ⁴⁾	1130 ³⁾ / 1195 ⁴⁾
H3 ²⁾	in	4.33	4.33	7.48	24.02	24.02	25.59	25.59	25.59
	mm	110	110	190	610	610	650	650	650
H5	Type 3277 in	3.98	3.98	3.98	-	-	-	-	-
	Type 3277 mm	101	101	101	-	-	-	-	-
Thread	Type 3271	M30 x 1.5			M60 x 1.5		M100 x 2		
	Type 3277	M30 x 1.5			-	-	-	-	-
α	Type 3271	G 3/8 (3/8 NPT)	G 3/8 (3/8 NPT)	G 3/8 (3/8 NPT)	G 3/4 (3/4 NPT)	G 3/4 (3/4 NPT)	G 1 (1 NPT)	G 1 (1 NPT)	G 1 (1 NPT)
α2	Type 3277	G 3/8	G 3/8	G 3/8	-	-	-	-	-

1) Height with welded-on lifting eyelet or height of eyebolt according to DIN 580. Height of the swivel lifting hook may differ. Actuators up to 355 cm² without lifting eyelet

2) Minimum clearance required to remove the actuator

3) Height for version with welded-on lifting eyelet (material EN-JS1030)

4) Height for version with female thread (material 1.5638/A352 LC3)

Table 6: Weights for standard version of Type 3296-1 and Type 3296-7
Table 6.1: Type 3296 Valve

Valve	NPS	1/2	1	1 1/2	2	3	4	6	8	
Valve without actuator (approx.)	Class 150 and 300	lbs	26	On request		77	128	165	419	On request
		kg	12			35	58	75	190	
	Class 600	lbs	On request			128	203	On request		
		kg				58	92			
	Class 900	lbs	On request	84	126	200	242			
		kg		38	57	91	110			

Table 6.2: Types 3271 and 3277 Pneumatic Actuators

Actuator	cm ²	350	355	700	1000	1400-60	1400-120	2800	2 x 2800			
Type 3271 (approx.)	Without handwheel	lbs	17.6	42	48.5	177	154.5	386	992	2095		
		kg	8	19	22	80	70	175	450	950		
	With handwheel	lbs	28.7	On request	59.5	Only with side-mounted handwheel (▶ T 8310-2)		On request				
		kg	13		27							
Type 3277 (approx.)	Without handwheel	lbs	26	42	57	-						
		kg	12	19	26							
	With handwheel	lbs	37	51	68							
		kg	17	23	31							

Dimensional drawings

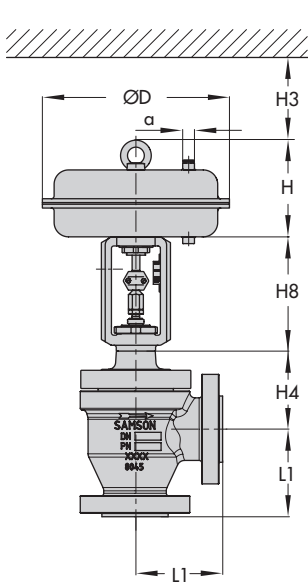

Type 3296 with Type 3271 Actuator

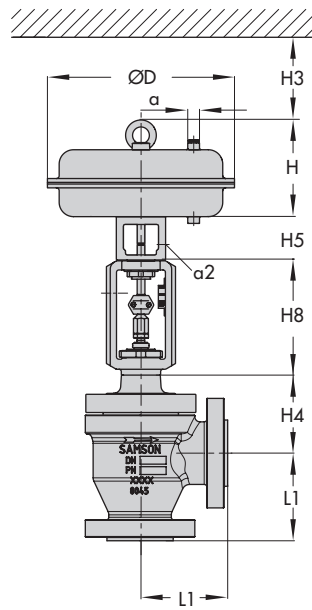

Type 3296 with Type 3277 Actuator

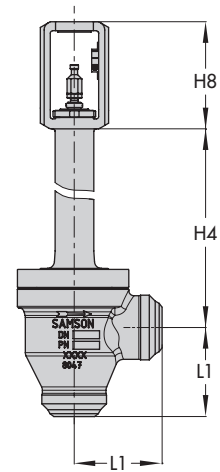

Type 3296 with bellows seal or insulating section

Table 7: Dimensions and weights for the standard version of Type 3296 with insulating section · Without actuator

Valve		NPS	½	1	1½	2	3	4	6	8
Class 300/600 H4 for actuator	350 cm ²	in	22.63	22.44	22.48	26.97	26.37	26.77	-	On request
		mm	575	570	571	685	670	680		
	355 cm ²	in	On request						-	
		mm	On request							
	700 cm ²	in	22.63	22.44	22.48	26.97	26.37	26.77	-	
		mm	575	570	571	685	670	680		
	1000 cm ²	in	-			On request				
		mm	-			On request				
	1400-60	in	-			29.13	28.54	28.93	38.5	
		mm	-			740	725	735	978	
1400-120	in	-						On request		
	mm	-						On request		
2800 cm ²	in	-						36.22	41.85	
	mm	-						920	1063	
Class 900 H4 for actuator	350 cm ²	in	23.85	23.85	23.85	28.62	26.37	26.77	-	
		mm	606	606	606	727	670	680		
	355 cm ²	in	On request						-	
		mm	On request							
	700 cm ²	in	23.85	23.85	23.85	28.62	26.37	26.77	38.5	
		mm	606	606	606	727	670	680	978	
	1000 cm ²	in	-			On request				
		mm	-			On request				
	1400-60	in	-			30.78	28.54	28.93	38.5	
		mm	-			782	725	735	978	
1400-120	in	-						On request		
	mm	-						On request		
2800 cm ²	in	-						36.22	41.85	
	mm	-						920	1063	
Weights										
Weight without actuator (approx.) for	Class 300	lbs	44	On request		95	146	207	463	On request
		kg	20			43	66	94	210	
	Class 600	lbs	On request	On request		146	220	On request		
		kg				66	100			
	Class 900	lbs	101	143	218	264	On request			
		kg	46	65	99	120				

Table 8: Dimensions and weights for the standard version of Type 3296 with bellows seal · Without actuator

Valve	NPS	½	1	1½	2	3	4	6	8					
Class 300/600 H4 for actuator	350 cm ²	in	22.52	22.32	22.36	31.26	30.67	30.27	-					
		mm	572	567	568	794	779	769						
	355 cm ²	in	On request							-				
		mm	On request											
	700 cm ²	in	22.52	22.32	22.36	31.26	30.67	30.27		45.98	56.89			
		mm	572	567	568	794	779	769		1168	1445			
	1000 cm ²	in	-			On request				-				
		mm	-			On request								
	1400-60	in	-			33.42	33.1	32.44		45.98	56.89			
		mm	-			849	841	824		1168	1445			
1400-120	in	-					On request			-				
	mm	-					On request							
2800 cm ²	in	-					39.72	49.33	60.24	-				
	mm	-					1009	1253	1530					
Class 900 H4 for actuator	350 cm ²	in	33.26	33.26	On request	30.67	30.27	-						
		mm	845	845		779	769							
	355 cm ²	in	On request						-					
		mm	On request											
	700 cm ²	in	33.26	33.26	On request	30.67	30.27		45.98	On req.				
		mm	845	845		779	769		1168					
	1000 cm ²	in	-			On request			-					
		mm	-			On request								
	1400-60	in	-			On req.	32.83		32.44		45.98			
		mm	-				834		824		1068			
1400-120	in	-					On request				-			
	mm	-					On request							
2800 cm ²	in	-					39.72	49.33	-					
	mm	-					1009	1253						
Weights														
Weight without actuator (approx.) for	Class 300	lbs	44	On request		95	146	207	463	On req.				
		kg	20			43	66	94	210					
	Class 600	lbs	On req.			On request		146	220	On request				
		kg						66	100					
	Class 900	lbs						101	143				218	264
		kg						46	65				99	120

Selection and sizing of the control valve

1. Calculate the C_v (K_{VS}) coefficient according to IEC 60534.
2. Select the valve size and C_v (K_{VS}) coefficient from Table 3 and Table 4.
3. Select the actuator and determine the permissible differential pressure from the Information Sheet ► T 8000-4.
4. Select the valve body material from Table 1 and Table 2 as well as from the pressure-temperature diagrams (see Information Sheet ► 8000-2).

The following specifications are required on ordering:

Valve size	NPS ...
Pressure rating	Class ...
Body material	According to Table 2
Type of connection	Flanges/welding ends
Plug	Standard or balanced
Facing	Soft seal, metal seal or high-performance metal seal
Characteristic	Equal percentage, linear or quick opening
Actuator	Type 3271 or Type 3277 (► T 8310-1 or ► T 8310-2)
Fail-safe position	Fail-close or fail-open
Medium	Density and temperature (other medium data, if required)
Flow rate	Under normal or operating condition as well as for various cases
Pressure	Upstream pressure p_1 and downstream pressure p_2 or differential pressure Δp for various cases
Valve accessories	Positioner and/or limit switches, solenoid valve etc, (Information Sheet ► T 8350)

Specifications subject to change without notice



SAMSON AG · MESS- UND REGELTECHNIK
Weismüllerstraße 3 · 60314 Frankfurt am Main, Germany
Phone: +49 69 4009-0 · Fax: +49 69 4009-1507
samson@samson.de · www.samson.de

T 8074-1 EN

2015-12-21 · English