

Series 250

Type 3254-1 and Type 3254-7 Pneumatic Control Valves

Type 3254 Globe Valve

DIN version



Application

Control valve for process engineering applications with high industrial requirements, particularly for high pressures and temperatures

Nominal size	DN 80 to 500
Nominal pressure	PN 16 to 400
Temperatures	-196 to +550 °C



Type 3254 Globe Valve operated with

- Type 3271 Pneumatic Actuator (Type 3254-1 Control Valve)
- Type 3277 Pneumatic Actuator (Type 3254-7 Control Valve) for integral positioner attachment

Valve body made of

- Cast steel
- Cast stainless steel, high-temperature cast steel or cast cold-resisting steel
- Special materials

Low-noise valve plug

- Metal seal
- Soft seal up to PN 40
- High-performance metal seal
- Balanced to handle high differential pressures
- Additional plug stem guide in the bottom body flange

The control valves, designed according to the modular assembly principle, can be equipped with various accessories: Positioners, limit switches, solenoid valves, and other accessories according to IEC 60534-6 and NAMUR recommendation (see Information Sheet ▶ T 8350 for more details).

Versions

Standard version with PTFE packing for temperatures from -10 to +220 °C or with adjustable high-temperature packing for -10 to +350 °C, nominal size DN 80 to 500, nominal pressure PN 16 to 400 (see Table 1)

- **Type 3254-1** (Fig. 1) · Type 3254 Valve and Type 3271 Actuator with 350 to 2800 cm² actuator area (see Data Sheets ▶ T 8310-1, ▶ T 8310-2, and ▶ T 8310-3)
- **Type 3254-7** · Type 3254 Valve and Type 3277 Pneumatic Actuator with 350 to 750 cm² diaphragm area for integral positioner attachment (see ▶ T 8310-1)

Further versions

- **Welding ends or welding-neck ends** according to DIN EN 12627
- **Flow divider or AC-1/AC-2/AC-3 Trim** for noise reduction See Data Sheets ▶ T 8081, ▶ T 8082, and ▶ T 8083
- **Valve plug with pressure balancing** · See Table 3



Fig. 1: Type 3254-1 Pneumatic Control Valve with Type 3271 Actuator

- **Perforated plug** · See Data Sheet ▶ T 8086
- **Insulating section or bellows seal** · See Technical data
- **Heating jacket** · Details on request
- **Additional handwheel** · See Data Sheet ▶ T 8310-1
- **ANSI version** · NPS 3 to 20, Class 150 to 2500 (see Data Sheet ▶ T 8061)
- **Type 3254 Valve with Type 3273 Hand-operated Actuator** For valves with max. 30 mm rated travel and side-mounted handwheel for travel > 30 mm · See Data Sheet ▶ T 8312
- **Type 3254-2 Electric Control Valve** · Details on request

Principle of operation

The medium flows through the valve in the direction indicated by the arrow. The valve plug determines the cross-sectional area of flow. The additional stem guide is located in the bottom body flange.

The version with bellows seal (Fig. 4) is fitted with a test connection to monitor the stainless steel bellows.

The valves can be equipped with a flow divider (Fig. 4, see Data Sheet ► T 8081) for noise reduction.

Pressure balancing must be used when high pressures or differential pressures act on the plug (Fig. 3).

Fail-safe position

Depending on how the springs are arranged in the pneumatic actuator (see Data Sheets ► T 8310-1, ► T 8310-2, and ► T 8310-3), the valve has two different fail-safe positions effective upon air supply failure.

- **Actuator stem extends (fail-close)**
The valve closes when the supply air fails.
- **Actuator stem retracts (fail-open)**
The valve opens when the supply air fails.

Differential pressures

The permissible differential pressures can be found in the Information Sheet ► T 8000-4.

Fig. 2 to Fig. 4 show configuration examples.

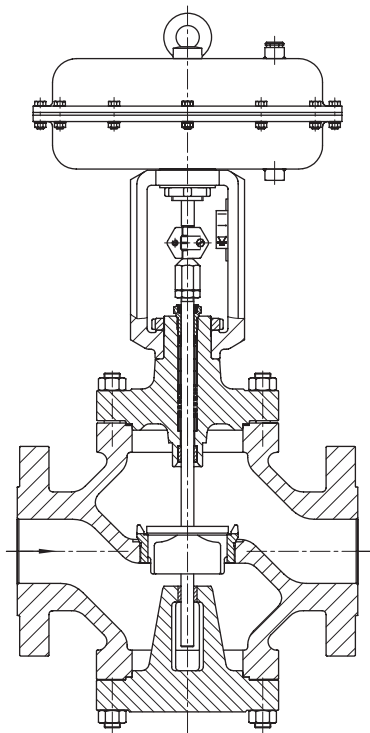

Fig. 2: Type 3254-1 Control Valve with Type 3271 Pneumatic Actuator

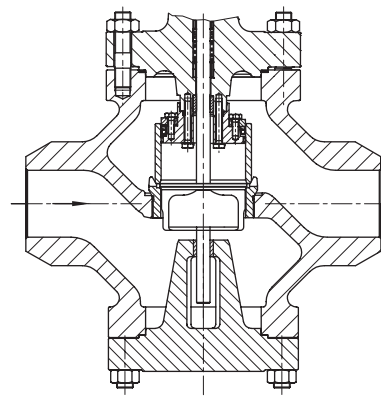

Fig. 3: Type 3254 Valve with welding ends and balanced plug

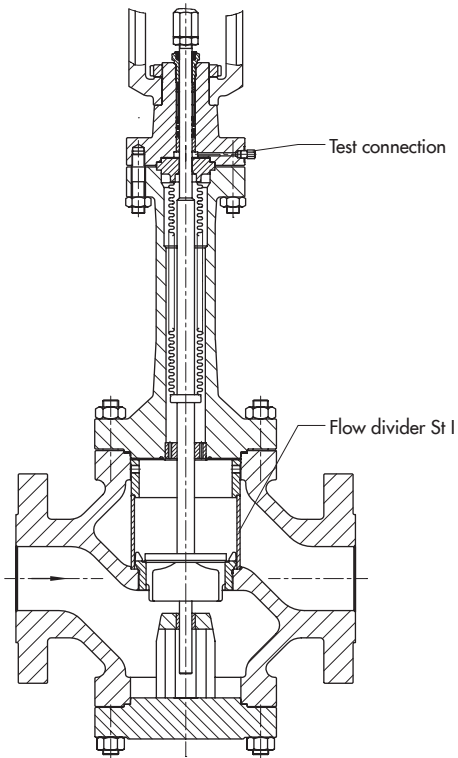

Fig. 4: Type 3254 Valve with flow divider St I and additional bellows seal with test connection

Table 1: Technical data for Type 3254

Material		Cast steel 1.0619		Cast steel 1.7357		Cast stainless steel 1.4408	
Nominal size ¹⁾	DN	80 to 150	200 to 300	80 to 150	200 to 300	80 to 150	200 to 300
Nominal pressure ¹⁾	PN	16 to 400	16 to 160	16 to 400	16 to 160	16 to 400	16 to 160
Type of connection	Flanges	All DIN EN versions					
	Welding ends	According to DIN EN 12627					
Seat-plug seal		Metal seal · Soft seal · High-performance metal seal					
Characteristic		Equal percentage · Linear · Quick opening (see Information Sheet ► T 8000-3)					
Rangeability		50:1					
Compliance		CE · EAC					
Temperature ranges in °C · Permissible operating pressures acc. to pressure-temperature diagrams (see Information Sheet ► T 8000-2)							
Body without insulating section		-10 to +220 °C · Up to 350 °C with high-temperature packing					
Body with insulating section or bellows seal		-10 to +400		-10 to +500		-196 to +550	
Valve plug ²⁾	Standard	Metal seal		-196 to +550			
		Soft seal		-196 to +220			
	Balanced with PTFE ring		-50 to +220 ³⁾				
	Balanced with graphite ring		220 to +550				
Leakage class according to IEC 60534-4							
Valve plug	Standard	Metal seal		Standard: IV · High-performance metal seal: V			
		Soft seal		VI			
	Balanced, metal seal		With PTFE ring (standard): IV · High-performance metal seal: V With graphite ring: IV				

¹⁾ DN 400: PN 16 to 100 · DN 500: PN 16 to 63

²⁾ Only in combination with suitable body material

³⁾ Lower temperatures on request

Table 2: Materials

Standard version Body ¹⁾		Cast steel 1.0619	Cast steel 1.7357	Cast stainless steel 1.4408
Valve bonnet		1.0460/1.0619	1.7335/1.7357	1.4408/1.4401
Seat and plug ²⁾ Seal ring for	Metal seal	1.4006/1.4008		1.4404/1.4409
	Soft seal	PTFE with 15 % glass fiber		
	Pressure balancing	PTFE with carbon · Graphite		
Guide bushings		1.4112		2.4610
Packing ³⁾		V-ring packing: PTFE with carbon; spring: 1.4310 · High-temperature packing		
Body gasket		Graphite seal on metal core		
Insulating section		1.0460/1.0619	1.7335/1.7357	1.4408/1.4401
Metal bellows seal				
Intermediate piece		1.0460/1.0619	1.7335/1.7357	1.4408/1.4401
Metal bellows		1.4571 ⁴⁾		
Heating jacket		1.4404		

¹⁾ Other materials (e.g. for high-temperatures or low temperatures) as well as special materials for applications with sea water, such as 1.4538, duplex 1.4470, nickel-based alloy 9.4610, see pressure-temperature diagrams in Information Sheet ► T 8000-2

²⁾ Seats and metal-seated plug also with Stellite® facing or plug made of solid Stellite® available (up to max. K_{V5} 630)

³⁾ Other packings on request (see Information Sheet ► T 8000-1)

⁴⁾ Other bellows materials on request

Table 3: Available K_{VS} coefficients · Versions highlighted in gray also available with balanced plug

Terms for control valve sizing according to IEC 60534, Parts 2-1 and 2-2: $F_L = 0.95$, $X_T = 0.75$

Table 3.1: Overview with flow divider St I ($K_{VS I}$), St II ($K_{VS II}$), and St III ($K_{VS III}$)

K_{VS}	63	100	160	250	360	630	1000	1500	2000	2500	3600
$K_{VS I}$	57	90	144	225	320	560	900	1350	1800	2250	3200
$K_{VS II}$	50	80	125	200	290	500	800	1200	1600	2000	–
$K_{VS III}$	47	75	120	190	270	480	750	1100	1500	1900	–
Seat \varnothing [mm]	63	80	100	125	150	200	250	300	350	400	500
Rated travel [mm]	30			60			120				

Table 3.2: Versions without flow divider · PN 16 to 400

K_{VS}	63	100	160	250	360	630	1000	1500	2000	2500	3600
DN											
80	•	•									
100	•	•	•								
150	•	•	•	•	•						
200		•	•	• ¹⁾	•	•					
250		•	•	• ¹⁾	•	•	•				
300			•	• ¹⁾	•	•	•	•			
400					•	•	•	•	•	•	
500							•	•	•	•	•

¹⁾ Pressure balancing only for \geq PN 63

Table 3.3: Versions with flow divider St I · PN 16 to 160 ¹⁾

$K_{VS I}$	57	90	144	225	320	560	900	1350	1800	2250	3200
DN											
80	•	•									
100	•	•	•								
150	•	•	•	•	•						
200		•	•	• ²⁾	•	•					
250		•	•	• ²⁾	•	•	•				
300			•	• ²⁾	•	•	•	•			
400					•	•	•	•	•	•	
500							•	•	•	•	•

¹⁾ PN 250 to 400 with flow divider St I and pressure balancing on request

²⁾ Pressure balancing only for \geq PN 63

Table 3.1: Overview with flow divider St I ($K_{VS I}$), St II ($K_{VS II}$) or St III ($K_{VS III}$)

K_{VS}	63	100	160	250	360	630	1000	1500	2000	2500	3600
$K_{VS I}$	57	90	144	225	320	560	900	1350	1800	2250	3200
$K_{VS II}$	50	80	125	200	290	500	800	1200	1600	2000	–
$K_{VS III}$	47	75	120	190	270	480	750	1100	1500	1900	–
Seat \varnothing [mm]	63	80	100	125	150	200	250	300	350	400	500
Rated travel [mm]	30			60			120				

Table 3.4: Versions with flow divider St II · PN 16 to 160 ¹⁾

$K_{VS II}$	50	80	125	200	290	500	800	1200	1600	2000	–
DN											
80	•	•									
100	•	•	•								
150	•	•	•	•	•						
200		•	•	• ²⁾	•	•					
250		•	•	• ²⁾	•	•	•				
300			•	• ²⁾	•	•	•	•			
400					•	•	•	•	•	•	
500							•	•	•	•	

¹⁾ PN 250 to 400 with flow divider St II and pressure balancing on request

²⁾ Pressure balancing only for \geq PN 63

Table 3.5: Versions with flow divider St III · PN 16 to 160 ¹⁾

$K_{VS III}$	47	75	120	190	270	480	750	1100	1500	1900	–
DN											
100	•										
150	•	•	•	•							
200		•	•	• ²⁾	•						
250		•	•	• ²⁾	•	•					
300			•	• ²⁾	•	•	•				
400					•	•	•	•	•		
500							•	•	•	•	

¹⁾ PN 250 to 400 with flow divider St III and pressure balancing on request

²⁾ Pressure balancing only for \geq PN 63

Table 4: Dimensions in mm for Type 3254-1 and Type 3254-7 in standard version

Table 4.1: Type 3254 Valve

Valve	DN	80	100	150	200	250	300	400	500	
Length L (flanges and welding ends)	PN 10 to 40	310	350	480	600	730	850	1100	1250	
	PN 63 to 160	380	430	550	650	775	900	1150 ³⁾	–	
	PN 250	450	520	700	–					
	PN 320	450	520	700	–					
	PN 400	570 ¹⁾	666 ¹⁾	908 ¹⁾	–					
Height H4	PN 10 to 40	222	242	314	387	442	655	640	760	
	PN 63 to 160					519		640 ³⁾	On req. ⁴⁾	
	PN 250 to 400	288	348	443	–					
H8 for actuator	350 cm ²	240	240	–						
	355 cm ²	240	240	418	–					
	700 cm ²	240	240	418	418	418	–			
	750 cm ²	240	240	418	418	418	–			
	1000 cm ²	295	295	418	418	418	On request			
	1400-60 cm ²	295	295	418	418	418	On request			
	1400-120 cm ²	480	480	503	503	503 ²⁾	650	650	650	
	2800 cm ²	480	480	503	503	503 ²⁾	650	650	650	
2x2800 cm ²	480	480	503	503	503 ²⁾	650	650	650		
H2	PN 10 to 40	175	207	288	390	410	480	560	630	
	PN 63 to 160	222	249	338	390	410	480	650	735	
	PN 250	280	311	442	–					
	PN 320	280	311	442	–					
	PN 400	280	333	450	–					

1) Face-to-face dimensions acc. to SAMSON standard

2) H8 = 650 mm with 250 mm seat bore

3) PN 63 and 100

4) PN 63

Table 4.2: Types 3271 and 3277 Pneumatic Actuators

Actuator area	cm ²	350	355	700	750	1000	1400-60	1400-120	2800	2 x 2800	
Diaphragm ØD	mm	280	280	390	394	462	530	534	770	770	
H ¹⁾	mm	82	121	199	236	403	287	490 ^{3)/} 580 ⁴⁾	630 ^{3)/} 695 ⁴⁾	1130 ^{3)/} 1195 ⁴⁾	
H3 ²⁾	mm	110	110	190	190	610	610	650	650	650	
H5	Type 3277 mm	101	101	101	101	–	–	–	–	–	
Thread	Type 3271	M30 x 1.5				M60 x 1.5			M100 x 2		
	Type 3277	M30 x 1.5				–	–	–	–	–	
α	Type 3271	G 3/8 (3/8 NPT)	G 3/8 (3/8 NPT)	G 3/8 (3/8 NPT)	G 3/8 (3/8 NPT)	G 3/4 (3/4 NPT)	G 3/4 (3/4 NPT)	G 1 (1 NPT)	G 1 (1 NPT)	G 1 (1 NPT)	
α2	Type 3277	G 3/8	G 3/8	G 3/8	G 3/8	–	–	–	–	–	

1) Height with welded-on lifting eyelet or height of eyebolt according to DIN 580. Height of the swivel lifting hook may differ. Actuators up to 355 cm² without lifting eyelet

2) Minimum clearance required to remove the actuator

3) Height for version with welded-on lifting eyelet (material EN-JS1030)

4) Height for version with female thread (material 1.5638/A352 LC3)

Table 5: Weights in kg for Type 3254-1 and Type 3254-7 in standard version**Table 5.1:** Type 3254 Valve

Valve	DN	80	100	150	200	250	300	400	500
Valve without actuator	PN 16 to 40	70	104	245	480	970	1081	1930	3200
	PN 63 to 160	121	158	375	On request	1345	On request		
	PN 250 to 400	On request							

Table 5.2: Types 3271 and 3277 Pneumatic Actuators

Actuator	cm ²	350	355	700	750	1000	1400-60	1400-120	2800	2 x 2800
Type 3271	Without handwheel	8	15	22	36	85	70	175	450	950
	With handwheel	13	20	27	41	190	175	300 ¹⁾ /425 ²⁾	575 ¹⁾ /700 ²⁾	On request
Type 3277	Without handwheel	12	19	26	40	-				
	With handwheel	17	24	31	45					

¹⁾ Side-mounted handwheel up to 80 mm travel

²⁾ Side-mounted handwheel above 80 mm travel

Table 6: Dimensions in mm and weights in kg for the standard version of Type 3254 with insulating section · Without actuator

Valve size	DN	80	100	150	200	250	300	400	500
Height H4	PN 10 to 160	492	512	665	947	1067	1151	1109 ¹⁾	On req. ²⁾
	PN 250 to 400	546	598	790	-				
Weight without actuator	PN 10 to 40	77	120	281	524	1050	On request		
	PN 63 to 160	128	175	411	On request	1405			
	PN 250 to 400	On request					-		

¹⁾ Up to PN 100

²⁾ Up to PN 40

Table 7: Dimensions in mm and weights in kg for the standard version of Type 3254 with bellows seal · Without actuator

Valve size	DN	80	100	150	200	250	300	400	500		
	Travel										
Height H4	PN 10 to 40	15 to 120	613	613	709	1024	1479	1514	1516	1590	
	PN 63 to 100	120	-				2381	2307	On request ¹⁾	-	
	PN 63 to 160	15 to 60	613	613	842	On request	1569	1635	On request ¹⁾	-	
	PN 250 to 320		855	663	On request	-					
	PN 400		1020	On request			-				
Weight without actuator	PN 10 to 40		85	128	300	570	1100	On request			
	PN 63 to 160		136	183	430	860	1460	On request	On request ¹⁾	-	
	PN 250 to 320		On request					-			
	PN 400		On request					-			

¹⁾ PN 100

Dimensional drawings

Type 3271 Pneumatic Actuator

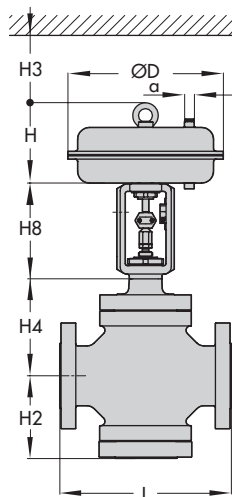

Type 3254-1

Type 3277 Pneumatic Actuator

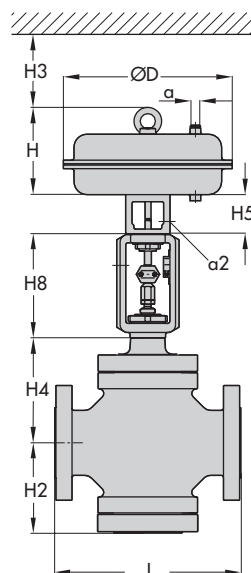

Type 3254-7

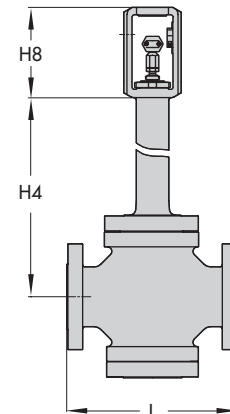

Type 3254 with bellows seal
or insulating section

Selection and sizing of the control valve

1. Calculate K_V coefficient according to IEC 60534.
2. Select nominal size DN and K_{VS} coefficient from Table 3.
3. Determine the permissible differential pressure from the Information Sheet ▶ T 8000-4.
4. Select the valve body material from Table 1 and Table 2 as well as from the pressure-temperature diagrams (see Information Sheet ▶ T 8000-2).
5. Select accessories from Table 1 and Table 2.

Order specifications:

Nominal size	DN
Nominal pressure	PN
Body material	According to Table 2
Bonnet	Standard bonnet, insulating section or bellows seal
Type of connection	Flanges/welding ends
Plug	Standard or balanced Soft seal, metal seal or high-performance metal seal
Characteristic	Equal percentage, linear or quick opening
Actuator	Type 3271 or Type 3277 (see Data Sheets ▶ T 8310-1, ▶ T 8310-2, and ▶ T 8310-3)
Fail-safe position	Fail-close or fail-open
Process medium	Density in kg/m^3 and temperature in $^{\circ}\text{C}$
Flow rate	kg/h or m^3/h in standard or operating state
Pressure	p_1 and p_2 in bar (absolute pressure p_{abs}), with minimum, normal and maximum flow rate
Valve accessories	Positioner and/or limit switch

Specifications subject to change without notice



SAMSON AG · MESS- UND REGELTECHNIK
Weismüllerstraße 3 · 60314 Frankfurt am Main, Germany
Phone: +49 69 4009-0 · Fax: +49 69 4009-1507
samson@samson.de · www.samson.de

T 8060 EN

2015-12-16 · English